



BUILDING INSPECTIONS IN FINLAND - FIGHTING AGAINST THE MOULDS

Nordic Building Fysic Symbosium | 01.06.2011 | Juhani Pirinen, DSc.

Presentation today:

1. How big is the mould problem in Finland?
2. Moisture damages – indoor air problems
3. A few words about microbes and health affects
4. Different approaches to estimate buildings
5. The health care point of view
6. Combined inspection method
7. Moisture and mould -programme

Joka Kodin Asuntomarkkinat

Etusivu Ohjelma Jaksot Kodinrakentajat Koti kunnossa Hyvä asuminen Asuntomarkkinat



Kosteusvauriot ja home kuriin talkoilla

0 kommenttia 0 pidän 0 en pidä

Hakeudu koulu Lisätietoja w

100 000 euron lasku

Perjantai 9.4.2010 klo 01:06

Janne K... ei aio lannistua, vaikka hometalohelvetit

AL: Talotehdas salaili kotiensä homeongelmaa

Mika Sillanpää / Talous-sanomat.fi

Lahti

- Etusivu
- Tuoreimmat
- Luetuimmat
- LAHDEN RADIO
- Radion etusivu
- Ohjelmat
- Radio Suomi
- Toimitus ja yhteystiedot
- Lähetä palautetta
- Lähetä juttuvinkki
- YLE Uutisten etusivu

Homeatalo on usein perhetragedia

Julkaistu 21.10.2009 klo 16:32, päivitetty 22.10.2009 klo 09:04



Asumistervi

HyväTerveys Terveys Mieli Liikunta Ravinto Keskustelut

Uusin lehti | Kilpaillut | Kevytkokki | Painonhallintavinkit | Kyvy lehdessä | Palaute | Tilaa lehti | Puoti

TERVEYS

Homeatalo tarvitsee remontin

Kun talo sairastuu, myös ihminen voi huonosti. On jatkuvaa nuhaa, poskiontelotulehduksia, yskää, astmaa. Lääkäri ei hometautia paranna, siihen tarvitaan remontti tai muutto.

Rakennuksen kosteus- ja homevaurioihin havahduttiin Suomessa parikymmentä vuotta sitten. Nykyisin ollaan kokolailla yksimielisiä siitä, että rakennusten homevauriot ovat terveysongelma, jota ei voi lakata maton alle. Ongelmana on

Aikuisen naisen terveysopas
Oppaaseen on koottu lukittua tietoa yli nelikymppisten naisten hyvinvoinnista. Oppaassa asiaa mm. **13,00 €**

HS.fi UUTISET

Keskiviikko 25.8.2010 | Loviisa Onnittele e-kortilla

Etusivu Uutiset Kulttuuri Viihde Urheilu Keskustelu Blogit On

Kotimaa Poliitikka Kaupunki Ulkomaat Talous Pääkirjoitukset Lukijoi

JUURI NYT > Kokoomuksen Katajan asema rikostutkinnassa yhä auki

Sairaaloiden homeet uhkaavat jo potilaiden henkeä

9.7.2010 5:45 Suosittelu 54

Uusi Suomi / Kotimaa

5 ohjetta hometalon tunnistamiseen -- "Mummu hajua ei ole"

Julkaistu 20.8.2010 11:07

Suomalaiset havahtuvat kotinsa homeongelmiin yleensä vasta terveyslaitosten ohjeiden myötä, kertoo rakennusterveysasiantuntija Hanna Rämö Uudelle Suomalaiselle. Rämön mukaan harva yrittää tarkkailla talon alapohjassa kasvavat sienet eivät välttämättä näy silmällä.



AAMULEHTI

Homeatalot: Yli 1000 talopakettissa vakavia rakennusvirheitä

15.08.2010 - 18:03 (17:37) KOMMENTIT: 12

Noin tuhannessa Älvsbyntalon ja vähintään sadassa Finnömon valmistamassa talopakettissa on käytössä määrätysten vastainen rakenneratkaisu. Näin sanovat useat Aamulehden haastatellut asiantuntijat.

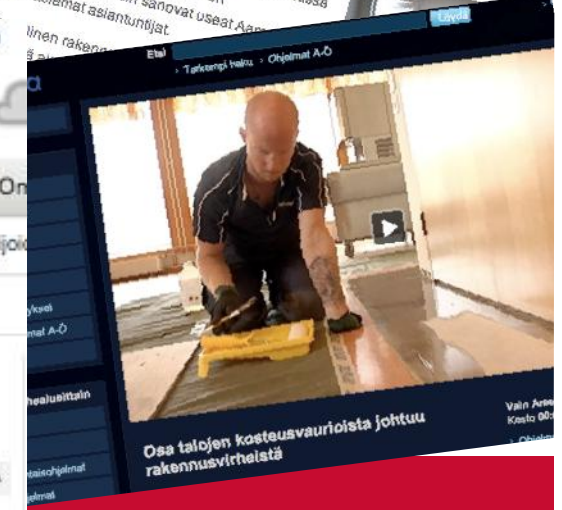

Mouldy buildings – a huge problem

- 1,1 million single family houses in Finland.
 - 25 % of the houses need repairing
- 56 000 block of flats
 - 6000-12000 need moisture damage-repairing
- In healthcare-branch there are about 8000 buildings
 - immediate repairs should be done in 25 %
- 9000 schools
 - immediate repairs should be done in 15 %.
- About 600 000 – 800 000 Finns are exposed to indoor air mould daily



Moisture damage – indoor air problems

- When moisture damages the building, it can cause indoor air problems like
 - mould growth
 - different chemical compounds from the building materials
- These can cause health problems for the inhabitants
- There are also many other physical and chemical phenomena that can cause same affects
 - airborne particles like mineral wool or asbestos fibres
 - radiation like radon
 - lack of ventilation, dirty incoming air systems etc.



Difficulties

- Separating all other phenomena from the microbial factors can be very difficult because they often operate in the indoor air simultaneously
- Many of the Finnish houses have a lot of problems at the same time
 - mould growth in structures
 - poor ventilation
 - radon
 - VOC, ammonium, aldehydes



Moisture damage - what is it?

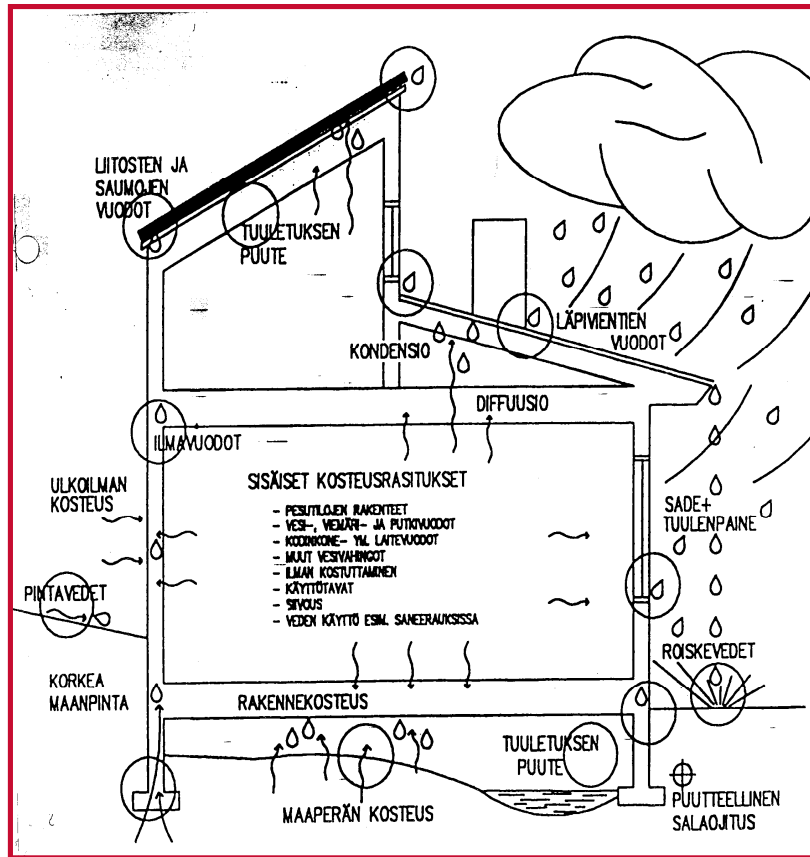

Kosteusvauriokorj. laadunvarmistus 1999, TTKK

- There are many different types of moisture damages
- They focus on different parts of the building, and originate from different sources of moisture
- Typical sources of moisture are:
 - rain and snow
 - ground moisture
 - moisture produced inside
 - water-pipes
 - air humidity

Reasons for moisture damages

- Most of the damages are caused by the leaks of the roof or piping
- Almost as many are caused by the wet soil under the houses (the capillarity forces)
- Also bathrooms have had poor waterproofing
- Poorly ventilated crawl spaces and roofs

- Old structures in Finnish houses have been very unsafe against moisture
- These houses are now old
- Combine these two things – you have a national mould problem

Mouldy buildings – why?

- Most of the Finnish houses were built in 1960s and 1970s, and should now be renovated the first time
- The renovations have delayed because:
 - the lack of the caretaking and renovating culture in real estate business
 - the owners have wrong opinions of the state of their buildings
 - Finns don't understand that buildings get old and must be rebuilt time to time



Problems in the base structures

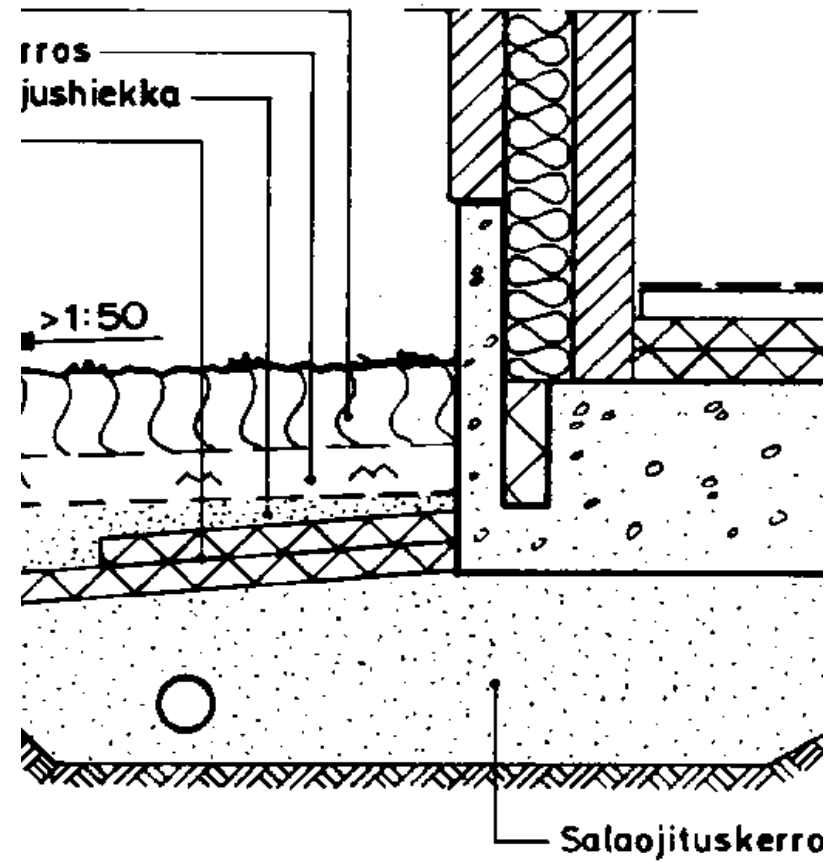
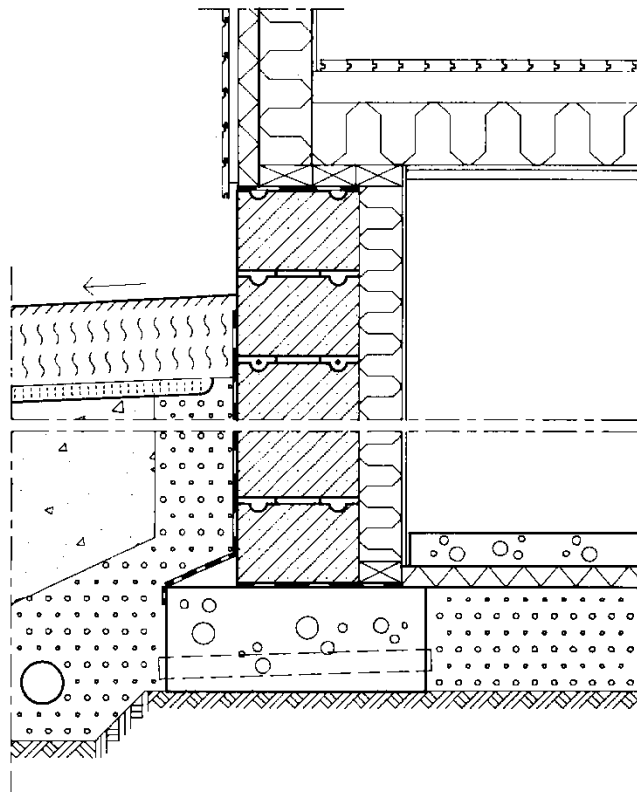

Damage – problem ?

- All building damages don't cause health effects
 - Carbonation and freezing damages of concrete
 - Rusting
- A building damage is a more general word that includes all the damages
- Indoor air problem include all the symptoms and other sensitive problems caused by damages or lacks in systems



Microbe damage - what is it?

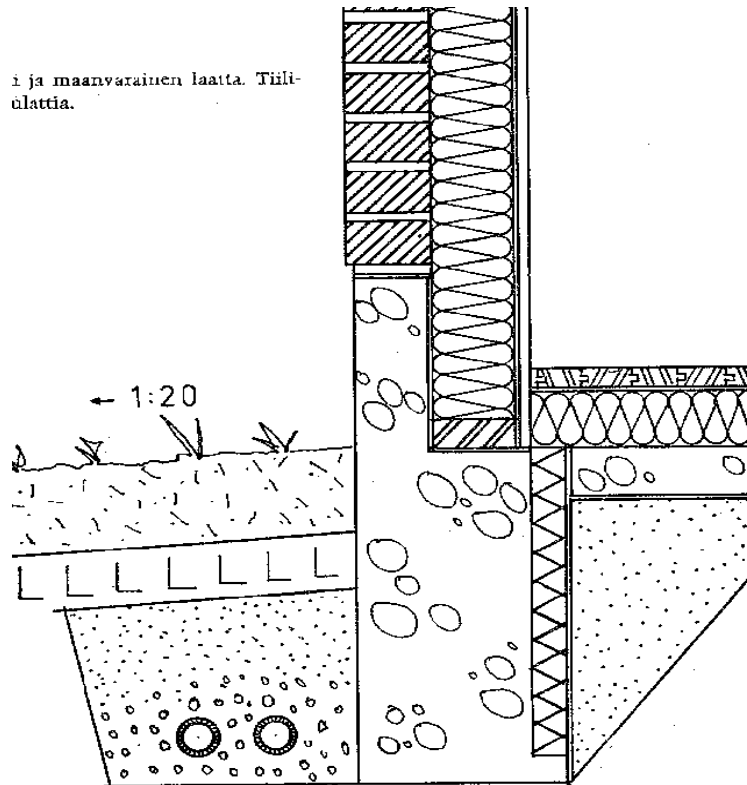

Matalaperustus, Rakennamme omakotitalon,
Paraisten Kalkkivuori Oy, v. 1968

- Microbes exist everywhere in nature
- They are always present in the exterior envelope of a building
- It is very difficult to determine when the microbe growth begins to be a damage
- Some species of microbes are typical to moisture-damaged buildings but are not the majority in nature.
- These species are called moisture damage indicators.

Limits for Microbial growth



- In Finland limits have been set to how much growth of the majority species is permitted in the structures
- The limits and the moisture damage indicators are presented in the Asumisterveysohje-guideline (healthy residence-guideline) published in 2003 by the Ministry of Social Affairs and Health)

Microbes don't need much

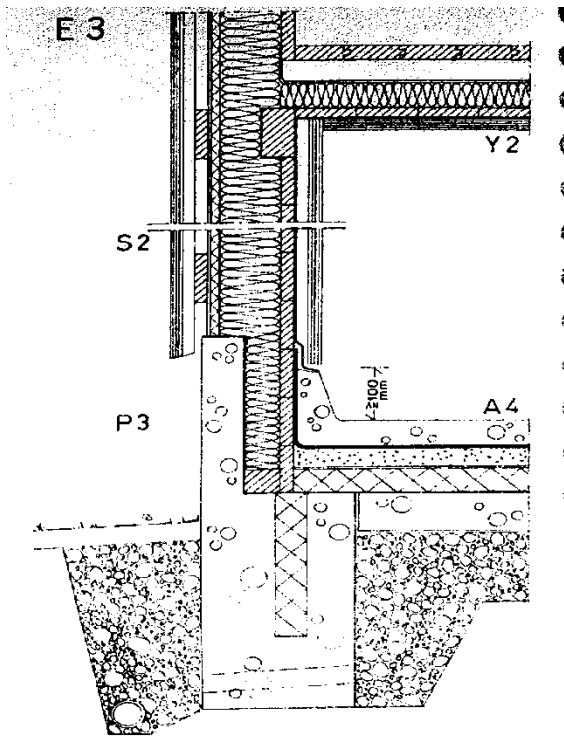

Jatkuvasti käytössä olevan saunan rakenteet, RT
913.52, 1966

- Microbes need nutrients, warmth and moisture
- Some microbes are able to live in rather low temperatures
- This means that there is warm enough for them to grow in the envelope of any building.
- Most building materials contain nutrients suitable for microbes.

Hidden mould

- One third of the severe mould problems are hidden inside the structures with no visible signs (Pirinen J. 2006)
- In 2/3 houses in which people are having health affects a severe mould problem is found (Pirinen J. 2006)
- Hidden mould can rarely be found without dismantling the structures
- Hidden mould is usually found by the expertise of the inspector



Microbe damage – health affects



- In Finland we believe that microbe damages in buildings affect the health of the inhabitants
- Excessive moisture in the interior surfaces or inside structures usually causes, eventually, the kind of microbial growth, which have an effect on human health
- This is an widely studied fact, which has been clarified in many studies globally
- However, the mechanisms of the health effects caused by microbe damages are poorly understood

Typical Health Effects of moisture- and mould damages (Torikka, K.1999)

	Health effect	Permanence
1. Irritation effects	common cold, blocked nose sore throat, hoarseness cough, phlegm, difficulty in breathing eye- and skin symptoms general symptoms, tiredness, headache, dizziness, nausea and concentration problems	no permanent health effect
2. Increasing amount of infections	recurrent infections respiratory infections inflammations of the ear or maxillary sinuses	diminishes after termination of exposure
3. Hypersensitivity diseases	allergy, usually rhinitis asthma alveolitis	may cause permanent health effects

Moisture and mould damages in schools

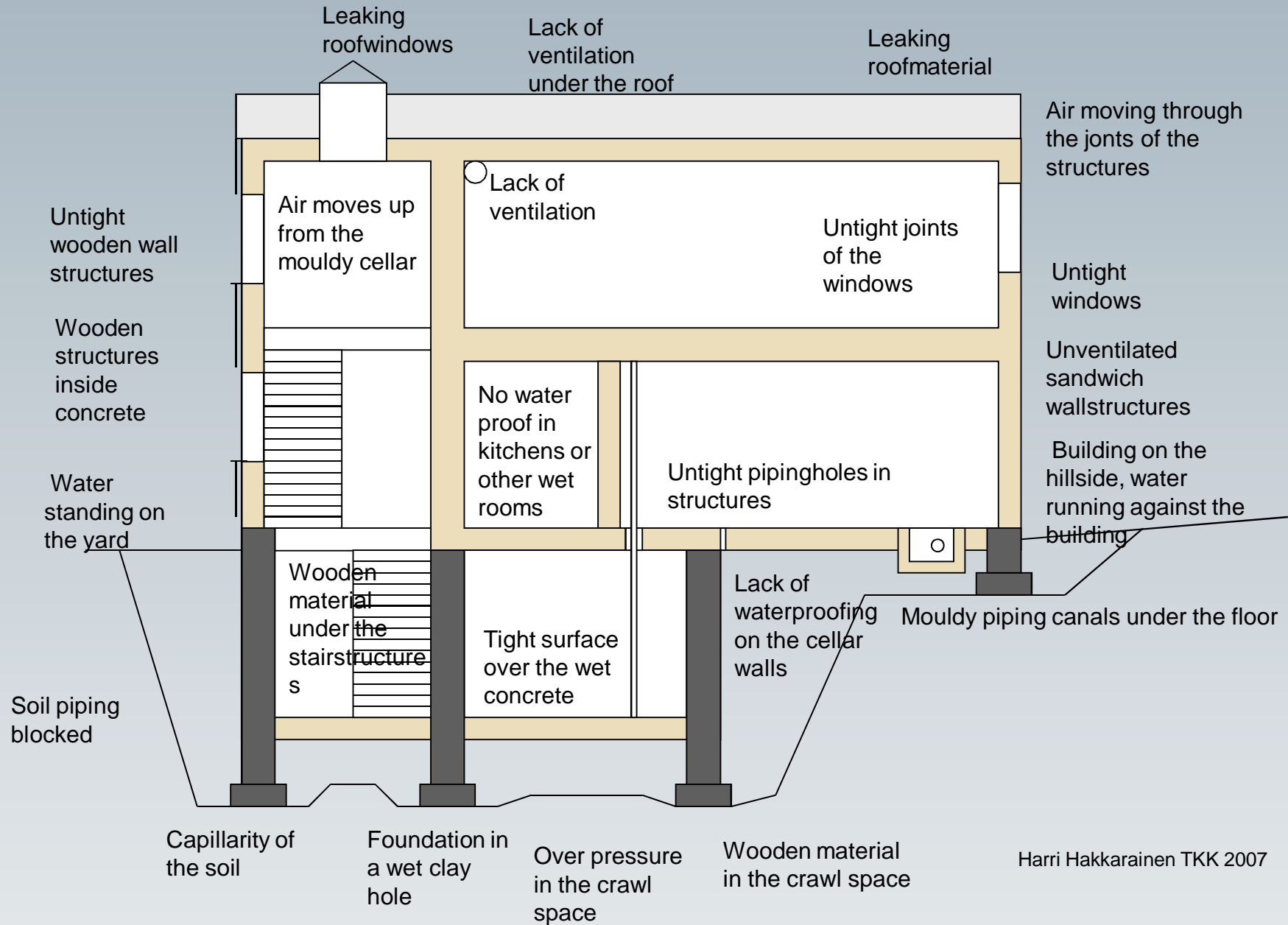

Two approaches to the building estimations

- The conservative one concentrates in building
 - the ageing of structures and materials, piping and ventilation systems
 - the costs of renovations
- The newer approach
 - the health affects for the inhabitants
 - the airborne particles and volatile compounds found in the air
- In Finland these two approaches have mixed together
- Very rare inspector can use both approaches correctly



Building inspection when selling or buying a house

- The method of the building inspection when selling or buying a house was first produced in 1999.
- The goal of this method was to standardise the building inspections performed when selling or buying a house and
- To offer reliable information to the seller and buyer about the true condition of the building.
- The building inspection is performed mainly by sensory and non-destructive methods.



The limits

- The scope of the inspection is set to the sensory level
- The report warns that the inspection does not necessarily expose the most severe damages
- If going through the documents or visual inspection leads to any suspect of constructional risks, should the inspector recommend the use of de-constructional methods
- But the decision to open the structures or do more measurements is always done by the owner of the property



Destructive testing of a moisture- or mould-damaged building

- The destructive testing of a moisture- or mould-damaged building –guide:
 - By the Ministry of the Environment
 - An instruction on how to plan, perform and analyse the results of the destructive testing methods of houses with indoor air problems
- The planning of a test programme
 - collecting of basic information (documents, occupant-interviews)
 - a risk estimation based on the documents and sensory inspection
 - composing the test and measurement programmes



Good – bad ?

- The guide is filled with specialised knowledge of the comprehensive testing of moisture damages
- The reader must possess basic theoretical knowledge about construction physics
- Guide presents a thorough model how to inspect buildings moisture problems
- Some critics have been presented the method to be too expensive
- That refers maybe to the lack of understanding among the real estate managers?



Destructive testing method (1997, Min.env.)

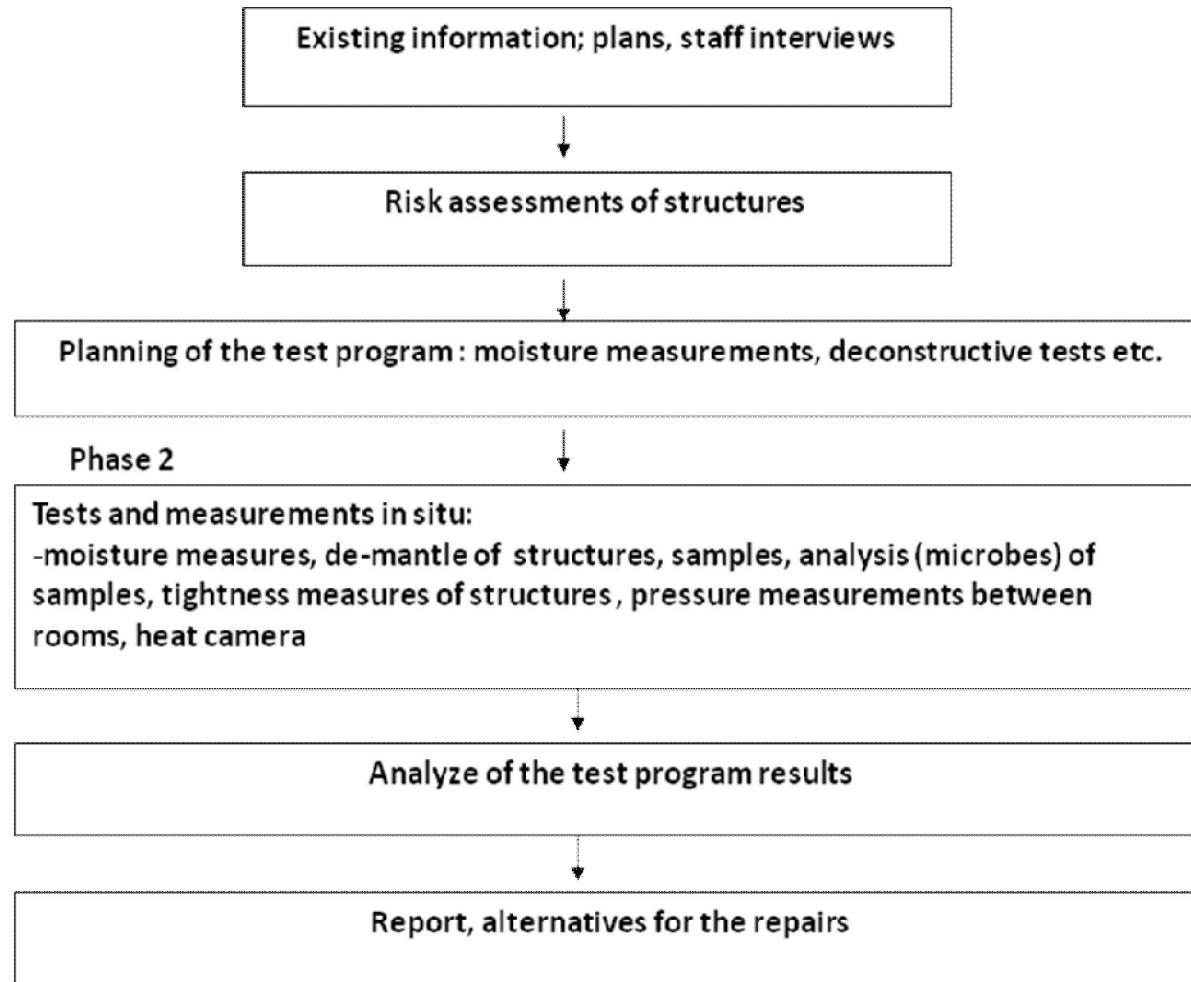

Other methods

- Indoor air condition testing (Finland's heat, water and air association)
- The guide to a condition assessment of small houses (Hekkanen, Martti)
- The basic condition assessment of an apartment building (Finnish Real Estate Organisation)
- Moisture damage assessment (National Public Health Institute's Laboratory of Environment)



Questionnaires

- questionnaires have been used since 1990s to estimate indoor air problems
- The mostly used is the MM-40 – questionnaire which is based on Swedish Örebro –model
- Finnish Institute of Occupational Health holds the rights to use this questionnaire in Finland and uses it a lot in surveys in working environments
- More specific symptom questionnaire is so called Tuohilampi -questionnaire, which was first published in 1996



Questionnaires- why?

- Questionnaires give a lot of information of the existence of indoor air problems
- They help to figure out the basis of the problem; whether it is mould or other microbes, lack of ventilation, VOCs or too high temperature
- Correctly used it can also show us in which parts of the building and what time of the year the symptoms occur
- the privacy law partly prevents its' use



The health care point of view 1/3



- The municipal board must ask the owner of the dwelling to renovate the health risk causing fact (Law of health care 1965)
- The mentioned pollutions or other problems were the lack of light or air, warmth or too much moisture, dirt, dust or vermin.
- The instructions for the health inspectors were published in 1980
- Parameters which can be measured were warmth, draught and air ventilation
- Committee for formaldehyde published limit values for formaldehyde in indoor air 1980
- In 1986 Government of Health together with Radiation Secure Center (STUK) published the limit values for radon in indoor air.

The health care point of view 2/3

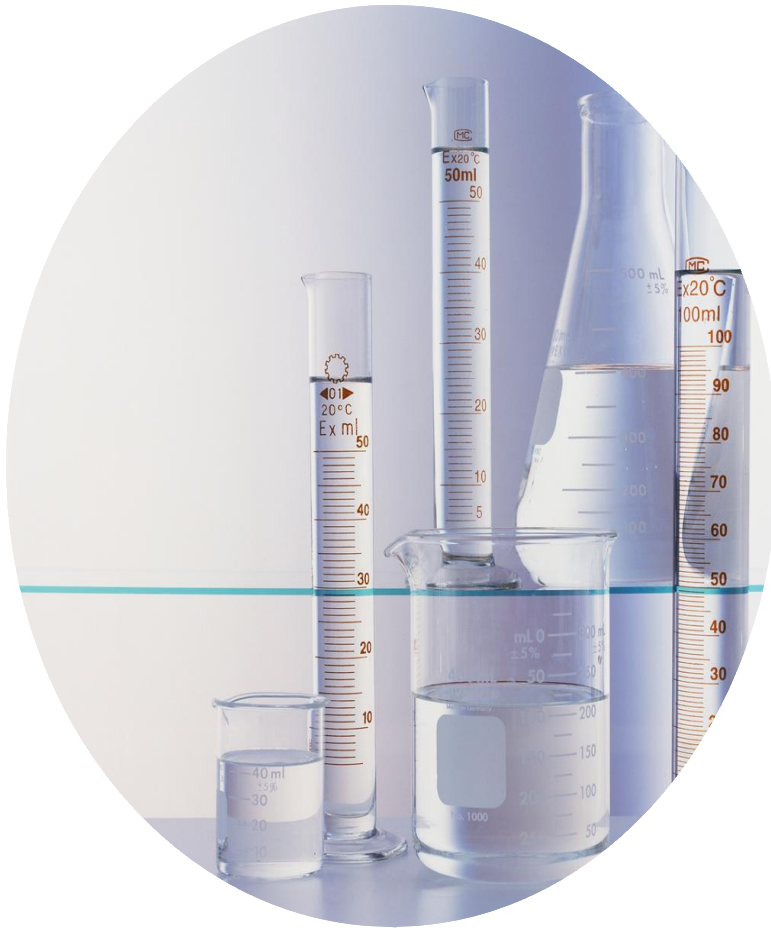

- Law of health protection 1995:
- The Ministry of Social Affairs and Health can give specific orders regarding the physical, chemical and biological factors in dwellings
- The first collection of regulations and instructions was named Sisäilmaohje (Indoor air-guideline) 1997
- It was replaced 2003 by Asumisterveysohje, Healthy dwelling-guideline, in which is included also many instruction and standards for instance of:
 - measuring moisture
 - detecting cigarette smoke
 - measuring mould and bacteria from air and surfaces and inside the structures

Anvisning om boendehälsa, is also found in swedish:

http://www.stm.fi/c/document_library/get_file?folderId=28707&name=DLFE-3897

The health care point of view 3/3



- The municipal health protection authorities must inspect inhabitants dwelling if the inhabitant suspects indoor air problem
- There don't need to be any mould growth in the dwelling, the condition for mould growth is enough
- Dwelling inspections are usually done by visual and non-destructive methods
- The municipal health protection authority can order the owner of the building to have the building inspected more thoroughly.

Problems on the field

- The two main approaches to buildings' indoor air problems and damages have mixed together
- Very rare experts can properly use all the tools which have been developed to the field of house inspections
- The owners of the buildings and the real estate managers are in deep trouble with these different guidelines and inspection methods
- New indoor air testing methods are coming to the market often untested and without any control



How to get better inspections?

- Combine the knowledge of the health sector and construction engineering sector
- Use the questionnaires to focus the inspections and tests
- Teach the house owners and real estate managers to use all reasonable methods
- Educate the inspectors:
 - Building physics
 - Old constructions
 - Microbiology
 - Other sources of impurities
 - Cooperation

Combined inspection method

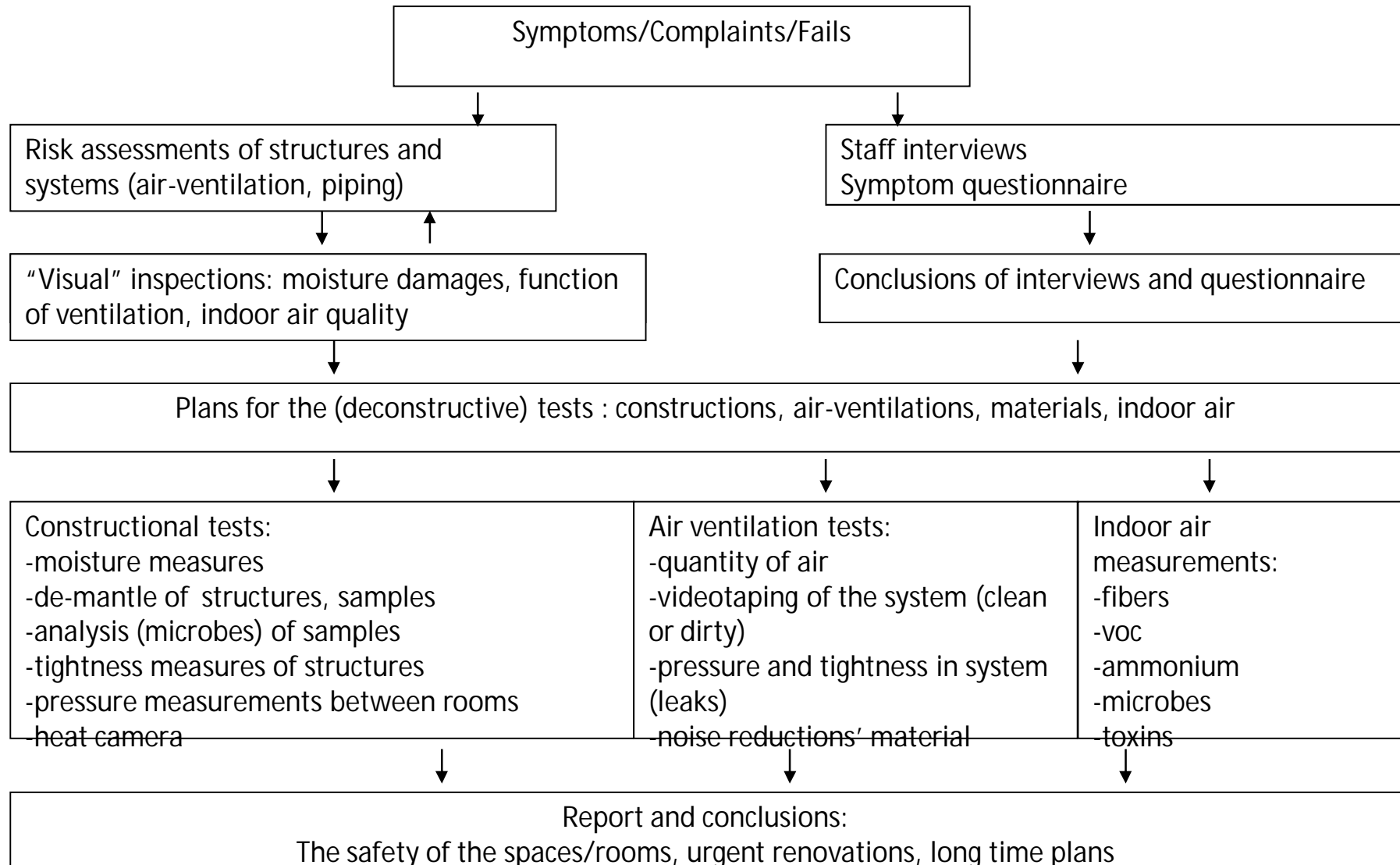

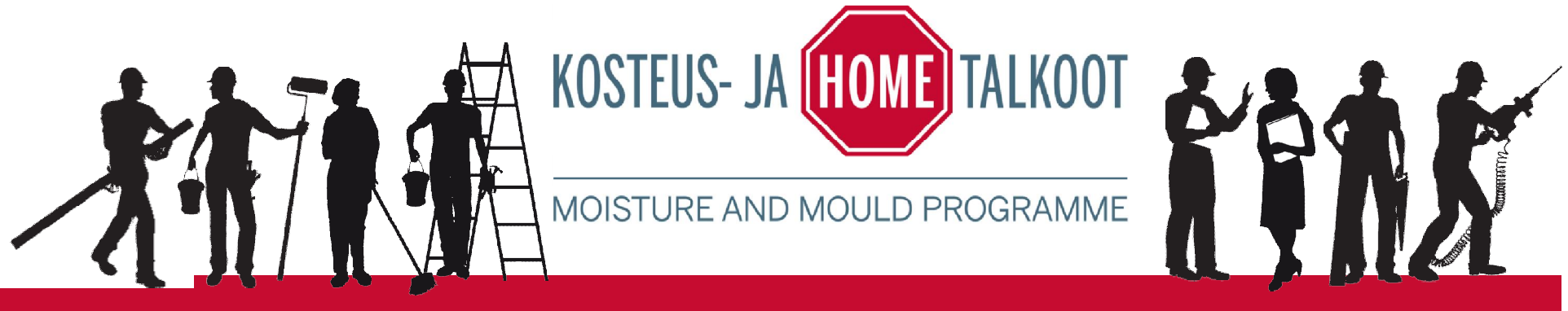

THE TARGET FOR THE PROGRAMME

- to diminish the health affects of the moulds
- to diminish the economical losses caused by the health affects of the inhabitants
- to prevent new mould problems to occur in future
- to make Finnish building stock healthy

Everything should be done a little better



ATTITUDE

Learn to own a house

Kuvat YM

Education - Design - Building - Use - Service - Repair

Programme timetable

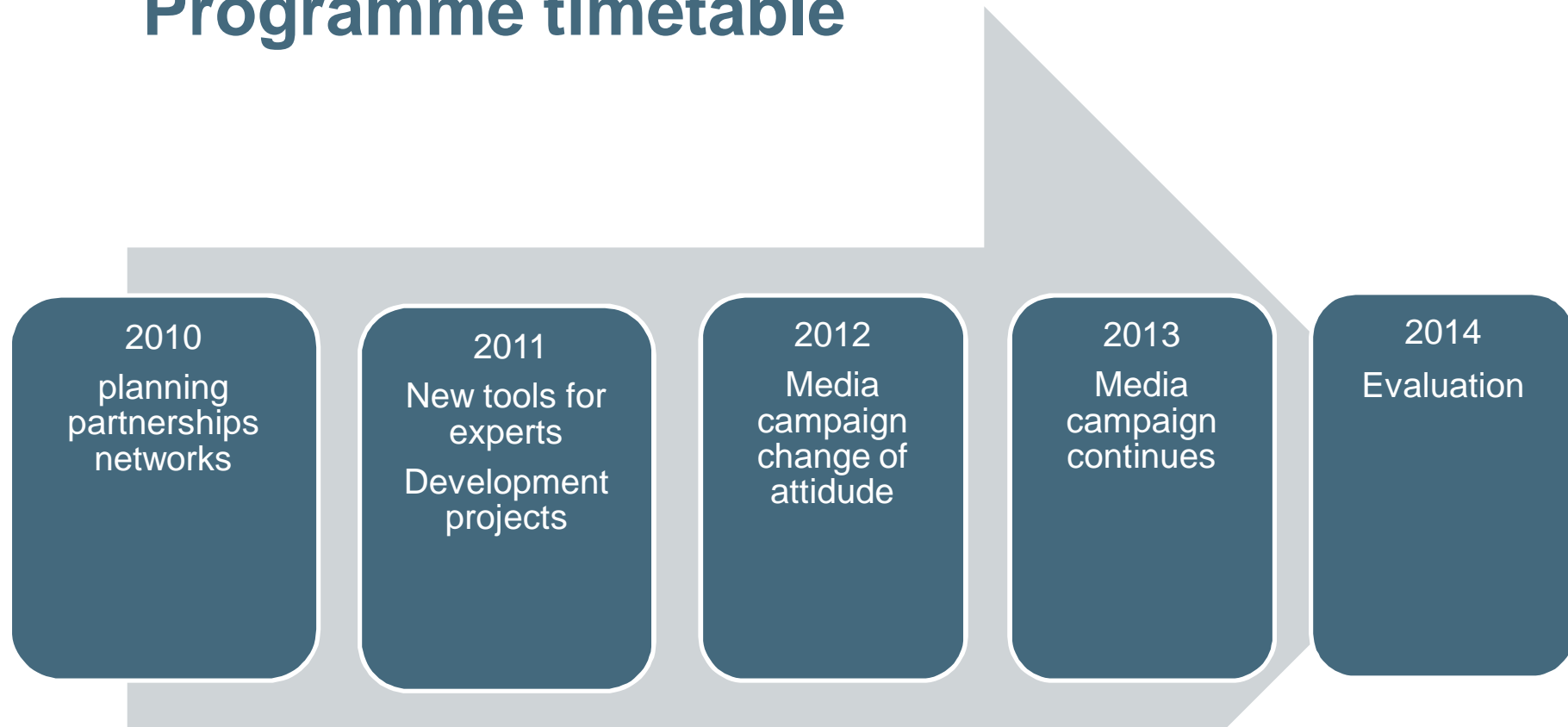

Tool 1.



Education of the inspectors and designers

*Helmi Kokotti,
University of Eastern Finland*

Tool 2.



Developing the security in house trading

- Tiina Koskinen-Tammi
- Leena Laurila
- Antero Pentikäinen

Tool 3.

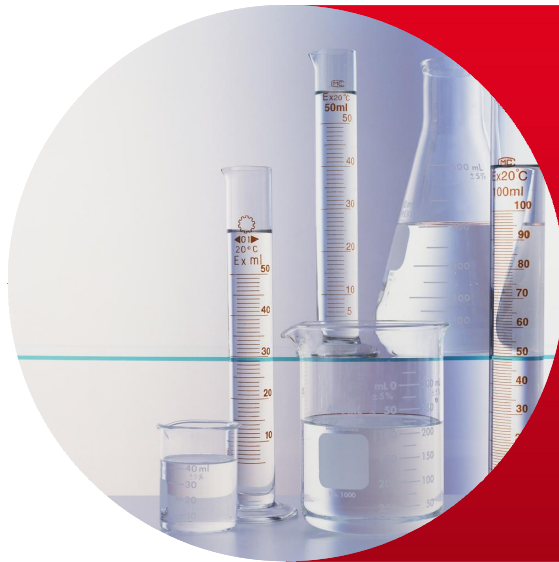

Research programme for mould toxins

Risto Aurola, HY, THL, TTL

Tool 4.



Governmental buildings

*Jukka Riikonen
Senaatti-kiinteistöt*

Tool 5.



Synchronising the guidelines

N.N.

Tool 6.



Developing the knowledge and attitude of the owners- media campaign

- N.N.

Got interested?

www.hometalkoot.fi

**finnish
swedish
english**

THANK YOU