

AnTherm

the software system for
Analysis of Thermal
behaviour of building constructions
with thermal bridges

<http://antherm.eu/>

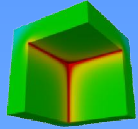

PRACTICAL IMPLEMENTATION OF A HARMONIC CONDUCTANCE MODEL IN THERMAL SIMULATION SOFTWARE

Calculation and visualization
of thermal heat flow by
tracing the transient heat streams.

Examples and capabilities available for such
calculations by using the three dimensional
simulation software AnTherm

T.Kornicki, Vienna, www.antherm.eu

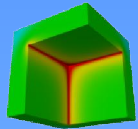

Tomasz Kornicki

- Physicist and computer scientist
- “IT Services” in Vienna, 23°
- Scientific and Management Consultancy since more than 25 years
- Software Tools for Building Physics
- Reliable partner for high performance simulation, supercomputing and (not only scientific) visualisation
- Lecturer at TU-Vienna, Danube-Univ. ,....
- International Building Performance Simulation Association

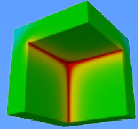

Decades of Transient Behaviour

- “Periodic heat flow – homogenous walls and roofs”
1944, Mackey C.O., Wrigth L.T.
- “Conduction of heat in solids”
1959, Carslaw H.S., Jaeger J.C.
- “Heat storage in walls and ceilings”
1974, Heindl W.
- “Wärmebrücken”
1987, Heindl W. Krec K., Panzhauser E., Sigmund A.
- “Heat loss to the ground from a building”
1988-1991, Claesson J., Hagentoft CE.
- “Heat storage in building constructions” ...
1993..., Krec K.,
- ...

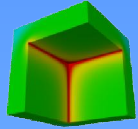

Concept of thermal conductances

- Introduced in „Wärmebrücken“ (Heindl1987) (thermal conductances and base solutions, g-values)
- Starting point for practical software implementations related to thermal bridges while assessing the risk of surface condensation in 2- and 3-dimensions
- Generalisations of earlier concepts towards dynamic heat transfer mechanisms involving thermal storage within buildings (Krec1993)
- Subsequently extended to include consideration of power sources (Krec1993), ventilation a.s.o.
- Practicality and Efficiency demonstrated in everyday use



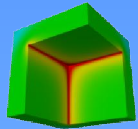

Concept of thermal conductances

- Well suited for modelling dynamic thermal behaviour under periodic boundary conditions
- Straight forward method for implementing in simulation software
- Employed in international norms and standards
- Multidimensional heat transfer mechanisms involving thermal storage
- Applicable in the field of dynamic simulation of time-dependant, transient thermal building behaviour
- Its practicality and efficiency of the harmonic approach often demonstrated

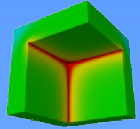

Periodic development

$$f(t) = \sum_{n=-\infty}^{+\infty} \hat{f}_n \cdot e^{-j \cdot \omega_n \cdot t} \quad \omega_n = n \cdot \frac{2 \cdot \pi}{T}$$

- any time dependant periodic entity can be developed by a *Fourier* series
- harmonic n
- complex amplitude of f_n

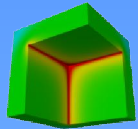

Heat loss

- the heat loss of a space i is given by integrating the heat flow density (heat flux) at the boundary of this space
- with Fourier's law applied

$$\hat{\Phi}_i^h = - \iint_{\mathcal{R}_i} (\lambda \cdot \text{grad } \hat{T}^h) \cdot d\vec{a}$$

- complex amplitude of the heat loss Φ_i
- boundary surface of the space \mathcal{R}_i
- λ thermal conductivity
- surface element oriented towards the space da ,

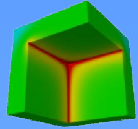

Base solutions

$$\hat{T}^h(x, y, z) = \sum_j \tilde{g}_j^h(x, y, z) \cdot \hat{\Theta}_j^h$$

- T complex amplitude of the h -th harmonic of the temperature oscillation in or at the component
- space number j
- complex base solution g_j („temperature weighting factor“)
- complex amplitude of air temperature θ_j

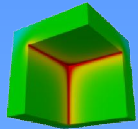

Harmonic Thermal Conductance

$$\hat{\Phi}_i^h = -\sum_j \hat{\Theta}_j^h \cdot \iint_{\mathcal{R}_i} (\lambda \cdot \text{grad } \tilde{g}_j^h) \cdot d\vec{a}$$

$$\tilde{\mathcal{L}}_{i,j}^h = \iint_{\mathcal{R}_i} (\lambda \cdot \text{grad } \tilde{g}_j^h) \cdot d\vec{a}$$

$$\hat{\Phi}_i^h = -\sum_j \tilde{\mathcal{L}}_{i,j}^h \cdot \hat{\Theta}_j^h$$

important note: the summation in j runs for all spaces (including i)

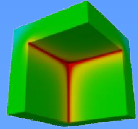

Periodic boundary conditions

The (yearly) mean value of heat losses of space i (steady state)

$$\bar{\Phi}_i = - \sum_{j=1}^N L_{i,j} \cdot \bar{\Theta}_j$$

The (yearly) oscillation of heat losses of space i (transient period of one year)

$$\hat{\Phi}_i = - \sum_{j=1}^N \tilde{L}_{i,j} \cdot \hat{\Theta}_j$$

important: The summation is to be executed through all N spaces connected to the model – this also includes the space i .

The time dependant distribution of heat losses during the year can be determined by a Fourier synthesis of the results for the entire building

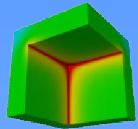

Standardisation, EN ISO Norms

- concepts have been incorporated in the “thermal bridge standard” EN ISO 12011
- additional standards (e.g., EN ISO 6946, 13370, etc.) made direct use of these concepts during the late 1990s
- generalisation of the concept to describe dynamic transmission processes involving heat capacity consideration under periodic boundary conditions established within EN ISO 13768.

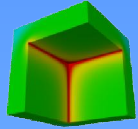

Special Case – single zone

- all interior spaces share the same temperature (1 zone)
- the exterior space is considered isotherm too

$$\bar{\Phi}_1 = -L_{1,0} \cdot \bar{\Theta}_0 - L_{1,1} \cdot \bar{\Theta}_1 = L_{1,0} \cdot (\bar{\Theta}_1 - \bar{\Theta}_0)$$

$$\hat{\Phi}_1 = -\tilde{L}_{1,0} \cdot \hat{\Theta}_0 - \tilde{L}_{1,1} \cdot \hat{\Theta}_1$$

Fourier synthesis yields:

$$\Phi_1(t) = L_{1,0} \cdot (\bar{\Theta}_1 - \bar{\Theta}_0) + |\tilde{L}_{1,0}| \cdot |\hat{\Theta}_0| \cdot \cos(\omega \cdot t + \varphi) + |\tilde{L}_{1,1}| \cdot |\hat{\Theta}_1| \cdot \cos(\omega \cdot t + \psi)$$

and by comparison with EN ISO 13370:2008-4 :

$$H_g = L_{1,0} \quad H_{pe} = |\tilde{L}_{1,0}| \quad H_{pi} = |\tilde{L}_{1,1}|$$

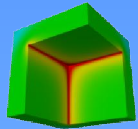

AnTherm simulation

- AnTherm stands for a powerful innovative software application for the building physics
- integrates new visualisation capabilities, which have their origins in supercomputing and in the scientific visualisation of large sets of physical data, in the daily life of a civil engineer
- features unavailable to building physicists only a short time ago are provided in AnTherm in an intuitively graspable way.
- employs extensive automation of the numerical models
- calculation results are (almost) immediately assessable
- high quality visualisations can be transferred directly into the reports

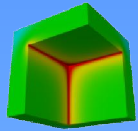

Implementation requirements of a simulation application

- thermal conductances (the matrix of thermal coupling) calculated directly without the need to specify any boundary conditions
- Standard conformant results, easily transferable to other simulation systems by a few simple manual calculations at most
- efficient support to evaluation of two- and three dimensional problems
- numerical stability of the method sufficient for most tasks (various levels of model detail like ground, foils, spaces)

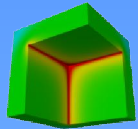

Implementation requirements of a simulation application

- integrated implementation for effective execution after a short learning period to ensure conscious control of the tool without specialised knowledge
- integrates itself into the everyday work process of an engineer, architect, building specialist or assessment expert
- address rare, occasional use
- seconds or, at most, a few minutes of computation when executed on typical office hardware

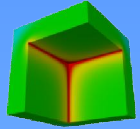

Implementation requirements of a simulation application

- enhance the enjoyment of exploring the thermal performance of buildings
- encourage the user to create optimised component variations
- support and facilitate insightful learning when used in the classroom

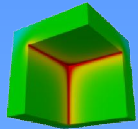

Numerical Solution

- finite difference model - linear system of equations derived from the heat transfer equation for the harmonic periodic model in the discrete space and represented by complex numbers
- linear system of several hundred thousand to a few millions of equations
- the solution vectors of base solutions for every period length contain the weighting factors (g-values) of respective cells (complex numbers as well)
- convergence assured by property “A” of the Jacobi matrix (iterative over-relaxation following Gauß-Seidl with varied relaxation factor) – related to symmetry and significantly dominant diagonal

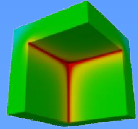

Numerical Solution

- only material cells taking part in the heat transmission included (instead of the whole volume)
 - Number of evaluated nodes is multiple of that:
 - 2D: cells x 4 = evaluated nodes
 - cell center, corners, mid-sides
 - 3D: cells x 8 = evaluated nodes
 - cell center, corners, mid-sides and mid-edges
- 20.000.000 equations = cells in 3D
→ more than 160.000.000 nodes



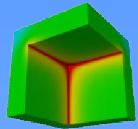

Foundation deep in ground dynamic transient problem Harmonic simulation in 3D

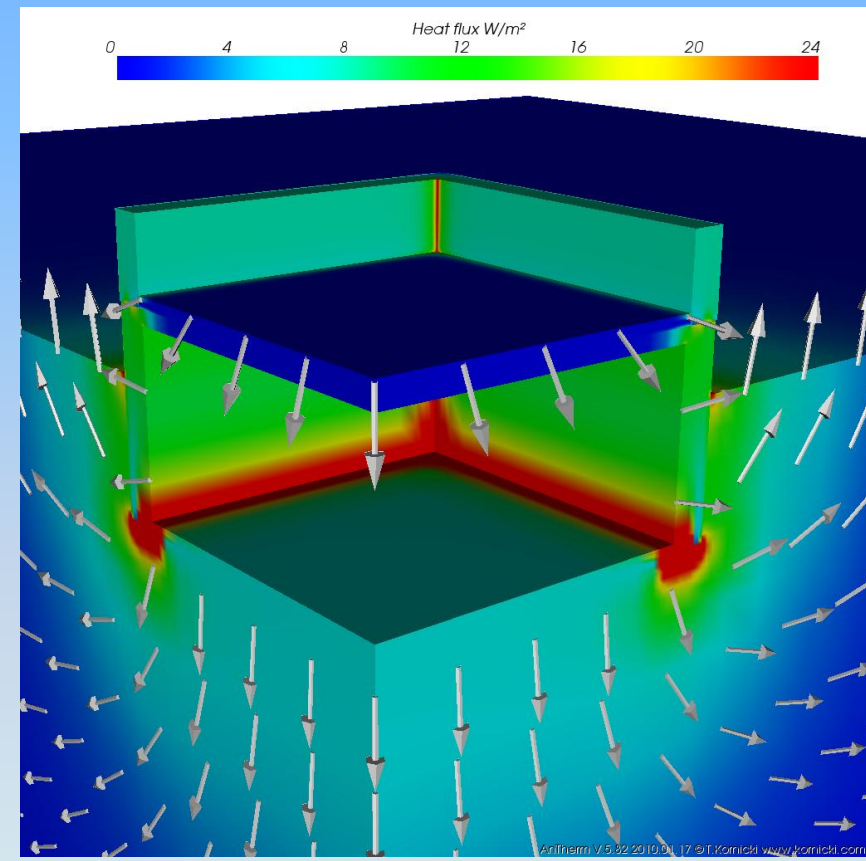
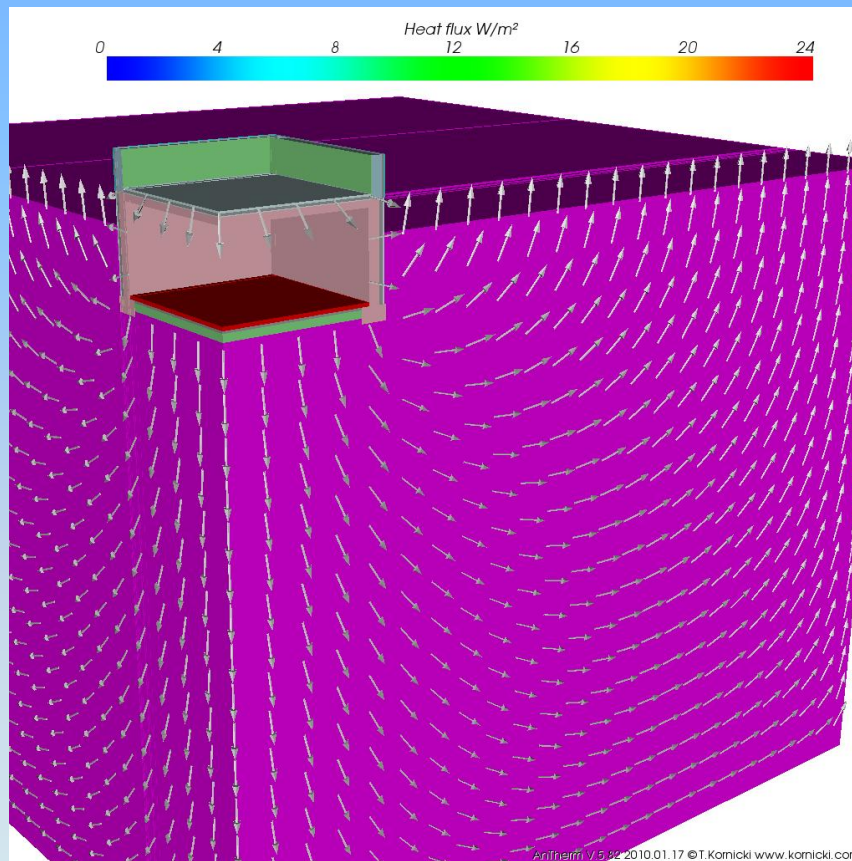

30 may 2011

(c) 2003-2011 T.Kornicki
<http://www.kornicki.com/>

20

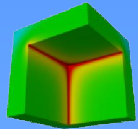

Harmonic thermal coupling coefficients and the phase lag between the oscillation of the temperature and the resulting variation of heat losses

- calculated directly
- independent of boundary conditions (no need to know them)
- shown as complex number and as the amplitude and phase lag

Thermal Coupling Coefficients [W / K]						
Space\Space	Room 0	Room 1	Room 2			
Room 0		2,116365	15,705269			
Room 1	2,116364		10,089766			
Room 2	15,705270	10,089766				

Steady state coefficient heat loss factor

Harmonic Thermal Conductance for the period of 31536000 s						
Space\Space	Room 0		Room 1		Room 2	
	Re	Im	Re	Im	Re	Im
Room 0	-372,1741	-343,2399	2,1133	-0,0619	7,2899	-2,9619
Room 1	2,1130	-0,0616	-12,2096	-0,4732	10,0850	-0,2123
Room 2	7,2866	-2,9647	10,0853	-0,2123	-28,3451	-6,3106

harmonic coefficient heat loss factor

Space\Space	Room 0		Room 1		Room 2	
	Amplitude [W/K]	Phase [months]	Amplitude [W/K]	Phase [months]	Amplitude [W/K]	Phase [months]
Room 0	506,2876	-4,5772	2,1143	-0,0559	7,8686	-0,7371
Room 1	2,1139	-0,0557	12,2187	-5,9260	10,0872	-0,0402
Room 2	7,8666	-0,7380	10,0876	-0,0402	29,0391	-5,5816

Amplitude

Phase-Lag

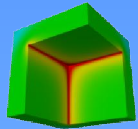

Interactive 2D and 3D visualizations

- “If houses could talk ...”
- support better understanding of thermal processes
- can easily be used as planning or component optimisation support, research or education
- state of the art computer-aided visualisation methods
- heat flow processes are easily “made perceivable”
- integrated in the highest quality to the desktops of building physics experts
- thermal bridges can be explored and examined in an almost playful, enjoyable manner

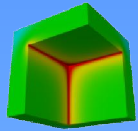

Slab over carport

Localising thermal bridges

Simulation in 2D and 3D

with

AnTherm

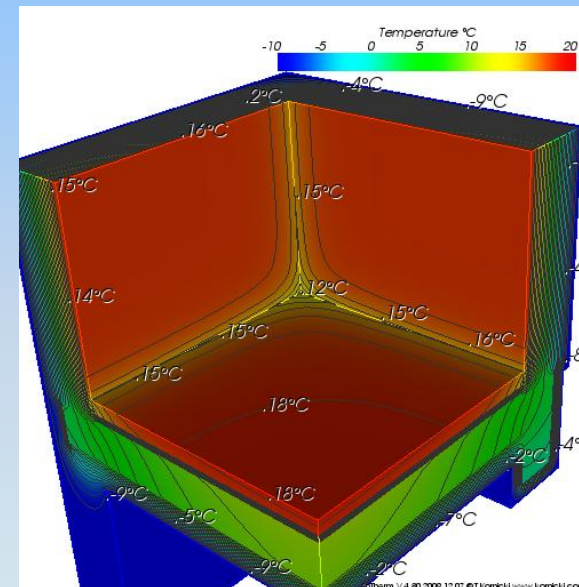
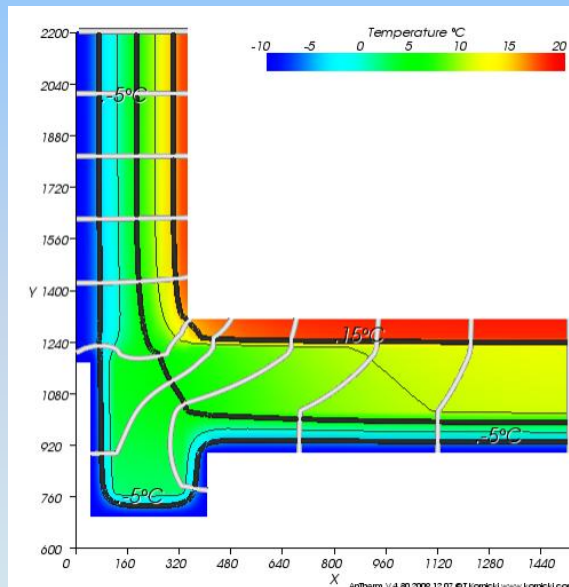

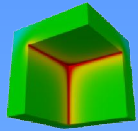

- Interactive Visualisation
- Identify the “Region of Interest”
- Qualitative investigation

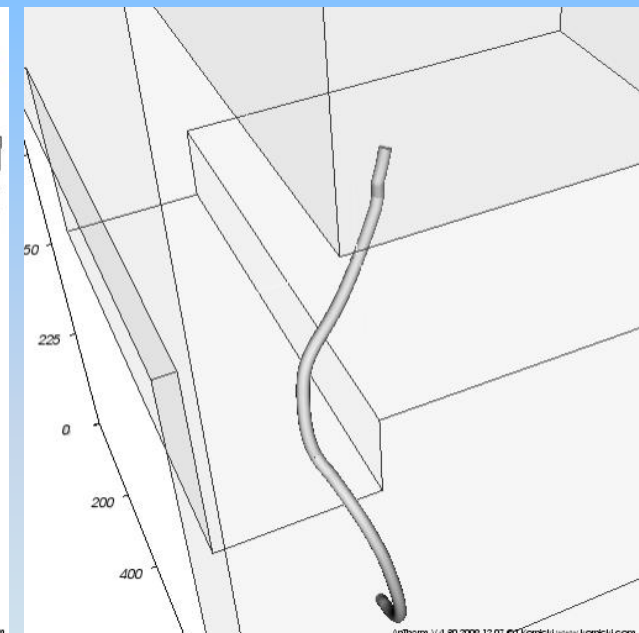
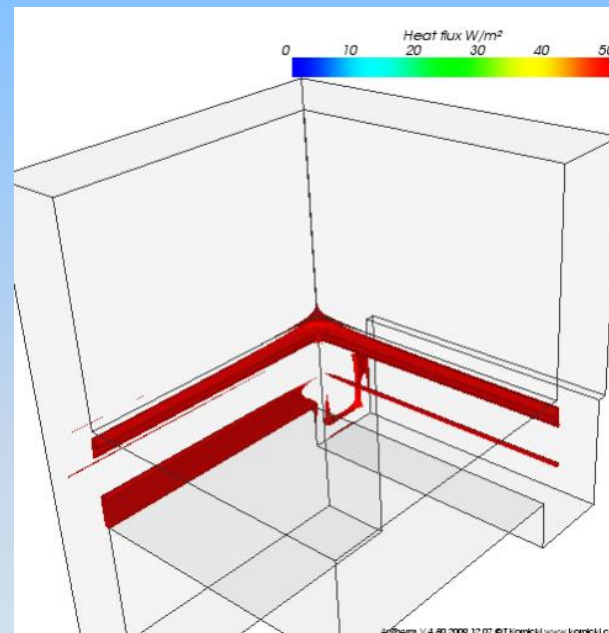
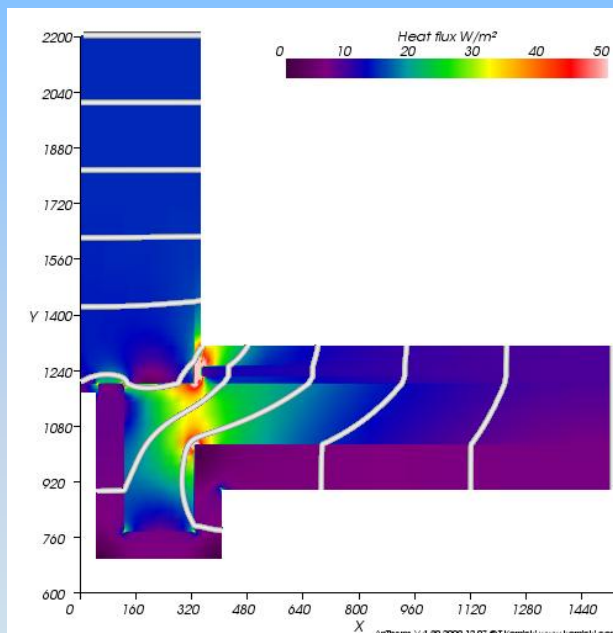

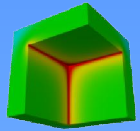

Groundwork

Simulation in 3D mit **AnTherm**

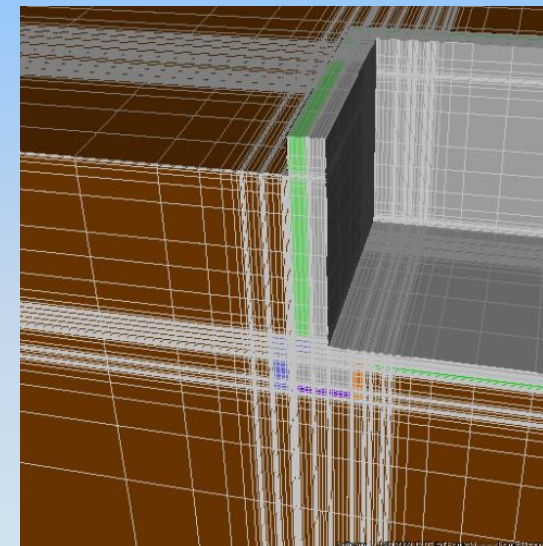
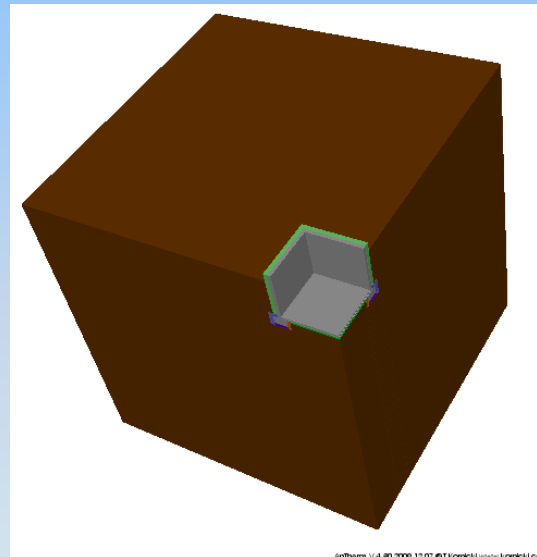
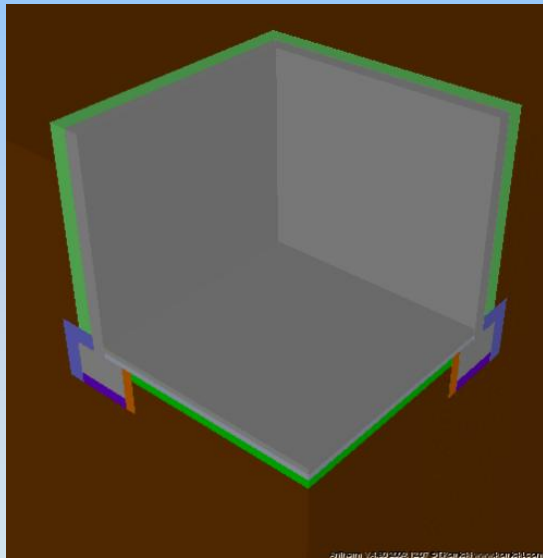

30 may 2011

(c) 2003-2011 T.Kornicki
<http://www.kornicki.com/>

25

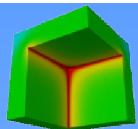

T.Kornicki, Dienstleistungen in EDV und IT
 A-1230 Wien, Othellogasse 1/RH 8/2
 Tel./Fax. +43-1-6157099
 email: tkornicki@chello.at

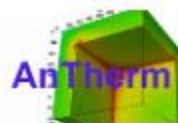

AnTherm (WALTER/UDO)
 Version 4.80 2009.12.07
 (c)T.Kornicki,all rights reserved

File: D:\Entw\01 Forum Passivhaus Poznan\Pyszczeck\STOPA FUNDAMENTOWA-01_tko.antherm

Number of evaluated cells: 538272 (Nodes > 4306176)

Boundary conditions and resulting Surface Temperatures / Condensing Humidity

	Air temperature [°C]	min.temperature [°C]	max.temperature [°C]	Condensing.H. [%]	f_{Rsi}^*
INDOOR	16,00	11,35	15,56	73,90 %	0,87
OUTDOOR	-20,00	-20,00	-19,51	100,00 %	

Boundary conditions

Extremes and surface condensation

Weigting factors for coldest surface point of each room

	INDOOR	OUTDOOR
g(INDOOR)	0,870846	0,000098
g(OUTDOOR)	0,129154	0,999902

Weighting factors (g-values)

Coordinates (x,y,z) for coldest surface point of each room

	x	y	z	Temp.[°C]	f_{Rsi}^*
INDOOR	-125,0000	-125,0000	800,0000	11,35	0,87
OUTDOOR	20000,0000	20000,0000	3700,0000	-20,00	

Critical locations

Thermal Coupling Coefficients [W / K]

Room\Room	INDOOR	OUTDOOR
INDOOR		6,741698
OUTDOOR	6,741750	

Coupling Coefficients (Thermal Heat Loss Factors)

Precision information

	Close-up error [W / K]	Coeff. sum [W / K]	Relative close-up error
INDOOR	5,29186e-005	6,741750	7,84938e-006
OUTDOOR	-5,29186e-005	6,741698	-7,84944e-006

Precision information (error estimates)

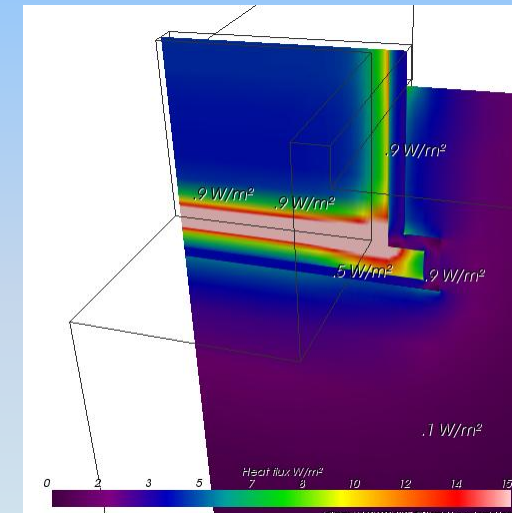
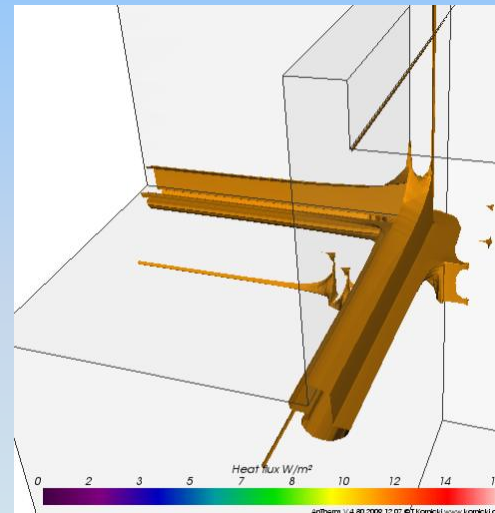
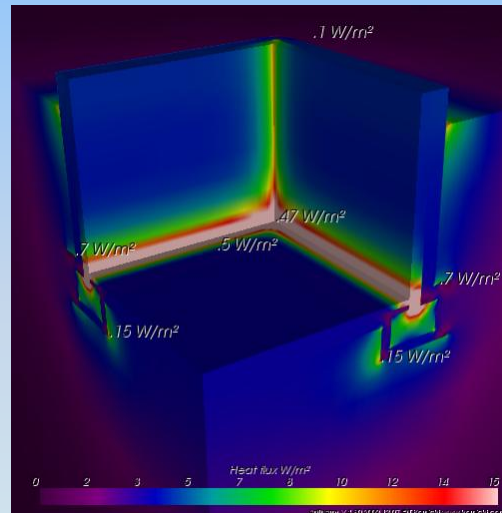
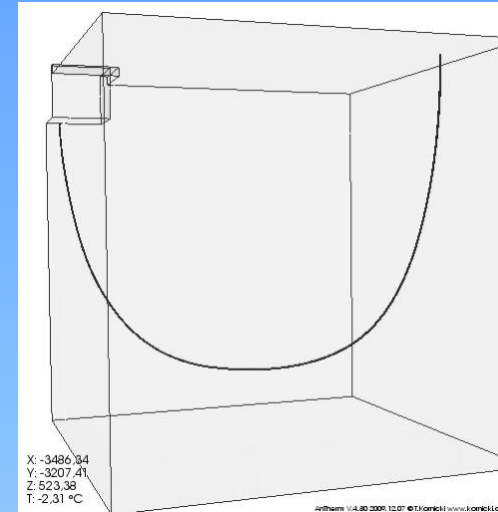
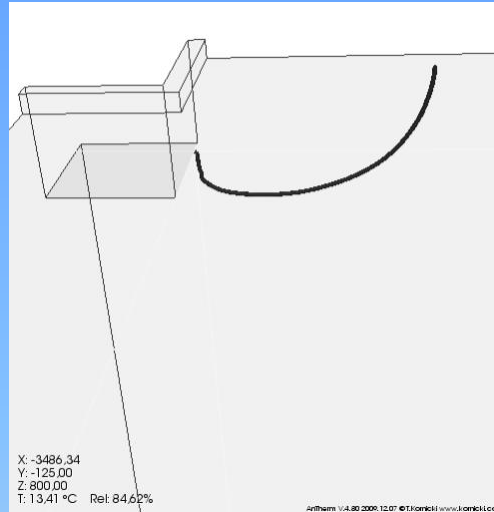
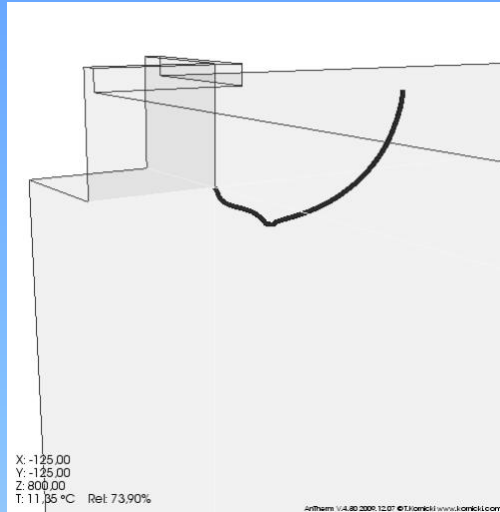
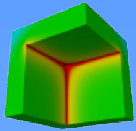

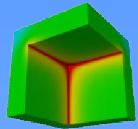

Future work

- further efficiency improvement of the harmonic- periodic transient calculation model
- extension of the visualisation techniques
- calculation, evaluation, and visualisation to be deployed on massively parallel systems

but

- continuing to respect the currently typical equipment of engineering bureaus
- 4D visualisation of time-dependant simulation results in immersive virtual environments is within reach

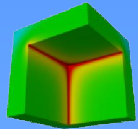

AnTherm

- AnTherm = the hymn (anthem)

In memoriam of **Dr. Walter Heindl** (†1994),
author of the concept of **Base Solutions** and the
Thermal Coupling Coefficients (Leitwerte)

- The kernel of these theoretical concepts have been directly adopted into the „**Thermal Bridge Standards**“ **EN ISO 10211**, thus stringent **conformity to the standard** is easily and automatically provided by **AnTherm!**

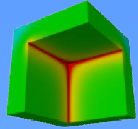

Trial instead of elaboration

- Fee demo version:

<http://www.antherm.eu/>

- Registration required (contact data)

- Example videos on YouTube:

<http://www.youtube.com/user/tkornicki>

- Imagery created with AnTherm on PicasaWeb:

<http://www.picasaweb.com/antherm>

- User Guide, Theory, Learning materials, Tutorials:

<http://help.antherm.eu/>

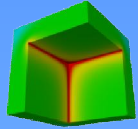

AnTherm

the software system for
Analysis of Thermal behaviour
in building constructions with thermal bridges

Contact:

<http://www.antherm.eu/>

E-Mail:

[antherm@antherm.at/](mailto:antherm@antherm.at)

Phone:

+43-1-6157099