

Development of a moisture safe connection for stud walls

Johan Jönsson & Miklós Molnár
Lund University, Sweden

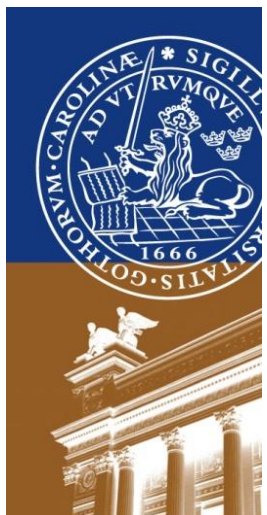

Lund University

Context

According to the Swedish National Testing and Research Institute, SP, almost 50 000 timber frame houses using ETICS are seriously damaged due to moisture penetration

Development of a robust moisture safe window connection for stud walls with different façade materials such as:

- Wooden panelling
- Sheet material
- ETICS

Increasing prefabrication potential and productivity

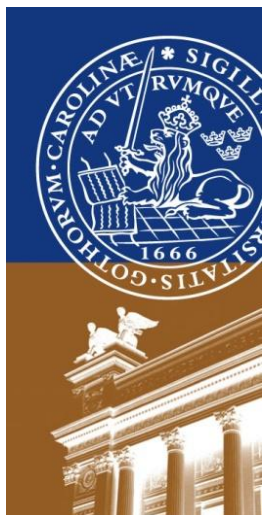
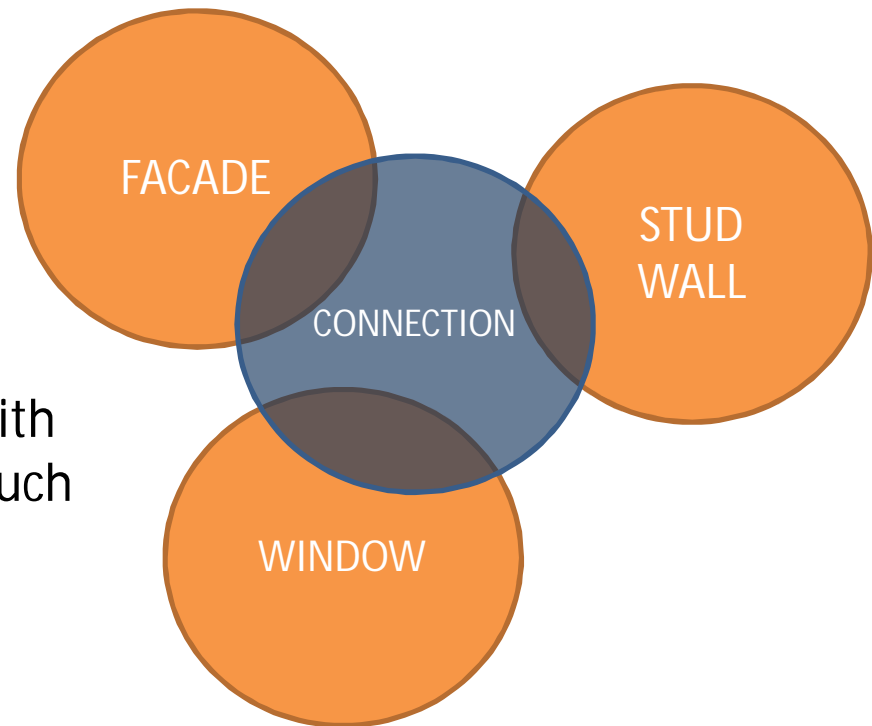



Lean Wood Engineering (LWE) is a competence centre for research and development within:

- Industrialized timber construction
- Wood manufacturing and interior solutions

LWE is designed as a joint-venture between:

- *VINNOVA*
- *Luleå Technical University*
- *Linköping University*
- *Lund University*

in collaboration with industrial partners from wood manufacturing industries as well as the building sector.

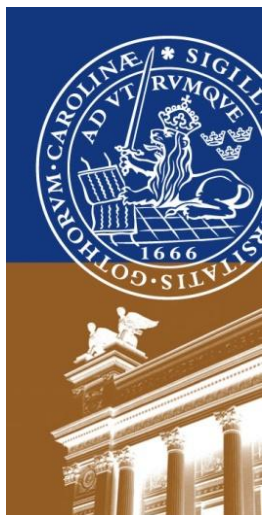

Establishing the requirements on the new window connection

- Collaboration with practitioners
- Brain storming with window manufacturers, facade experts, constructors and consultants
- Interviews with architects, building owners and prefabricated house manufacturers
- Site visits and case studies

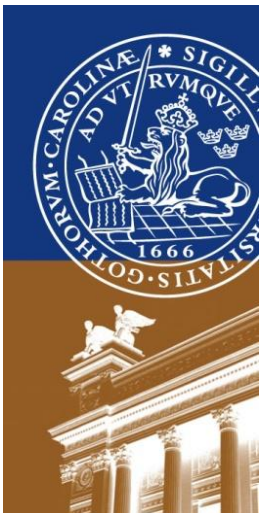

Moisture related requirements on a robust connection between stud walls and windows

- Water penetrating through the primary moisture barrier must be able to drain onto the window sheet
- Not sensitive to moisture that might accumulate in the pre-compressed sealing tape
- Possibility to have a water safe outer weather barrier, before the facade in question is mounted.

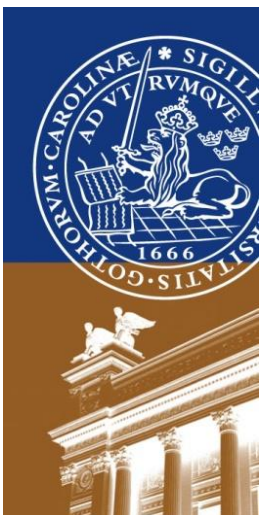

Requirements on an efficient mounting

- It should be possible to use different facade materials such as ETICS, wood panelling or sheets, using a single standard design for the window connection.
- The new connection should be prefabricated and easy to mount, without requiring special craft skills.
- Eliminate skewness and roughness in wooden battens and sheet materials closest to the window.
- Facilitate sealing by using a well-defined surface on the window connection.
- Possible to install the window after the facade is completed
- Possible to replace the window at any time without damaging the facade and window sheet.

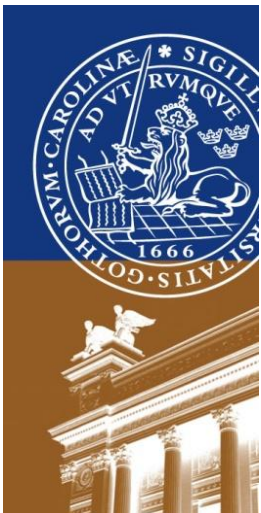

Preliminary design of the window connection – vertical section

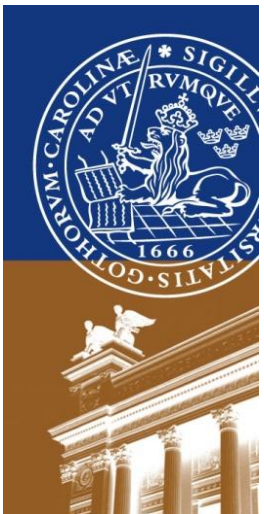
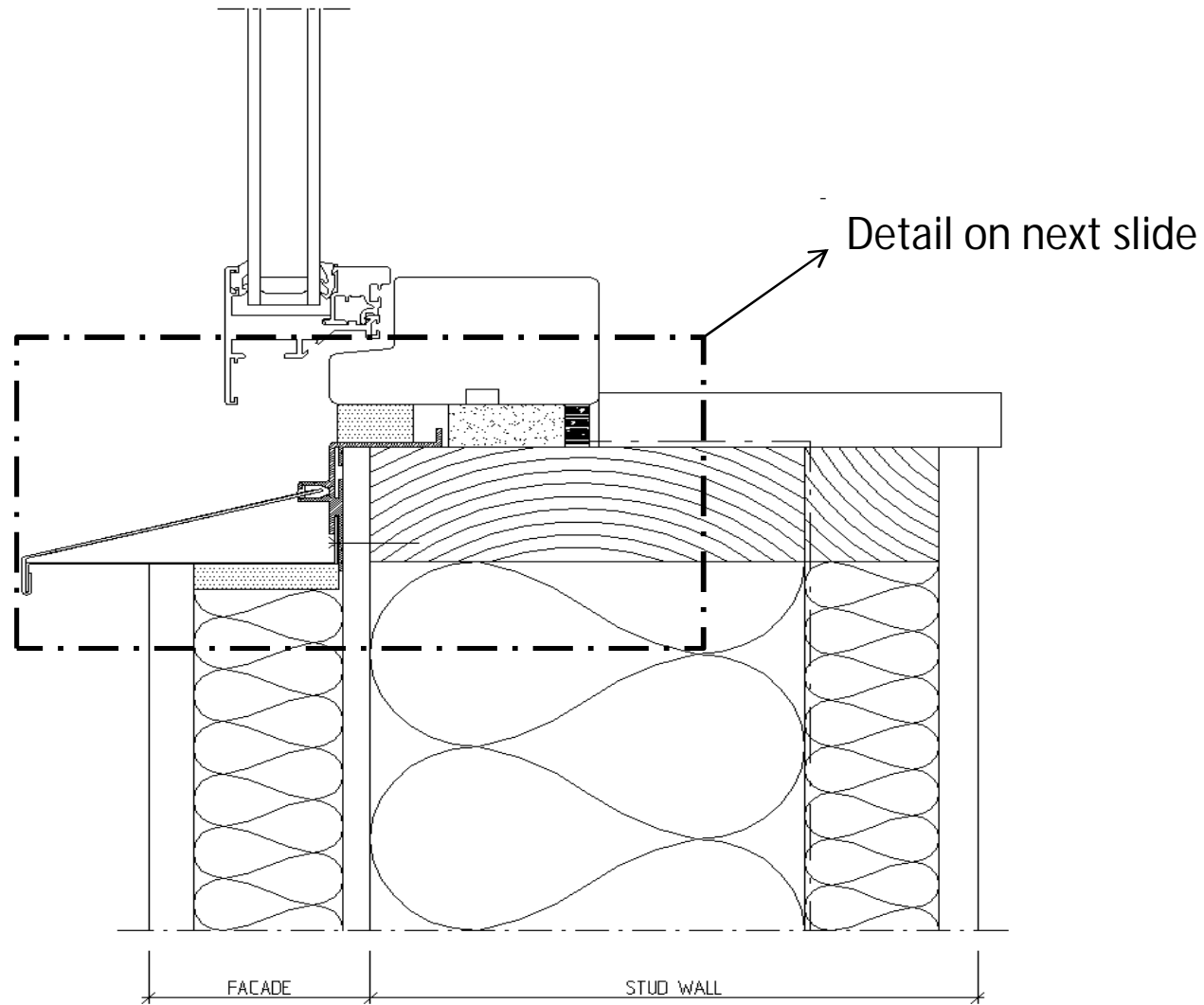

Detail – vertical section

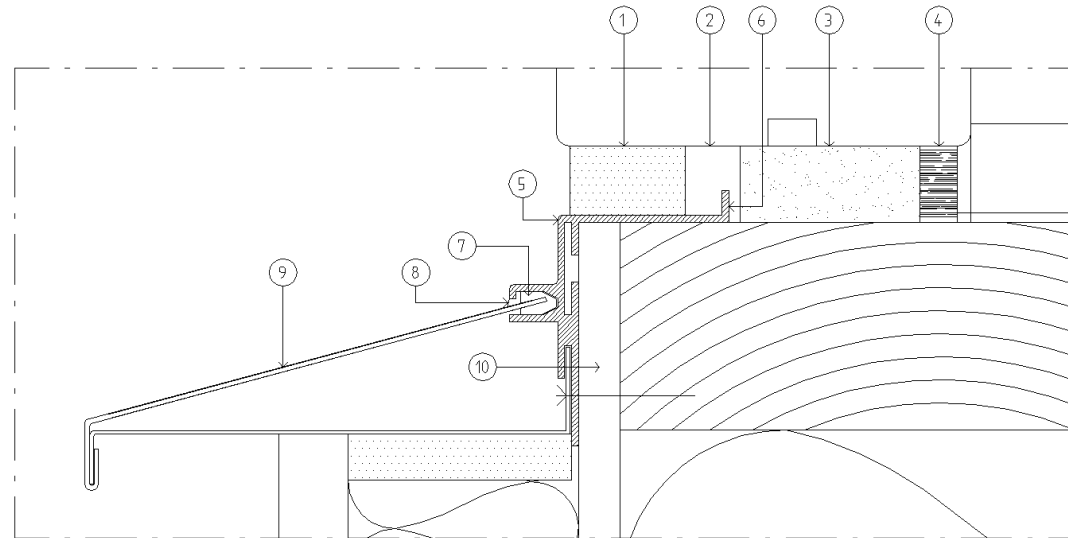

Prototype

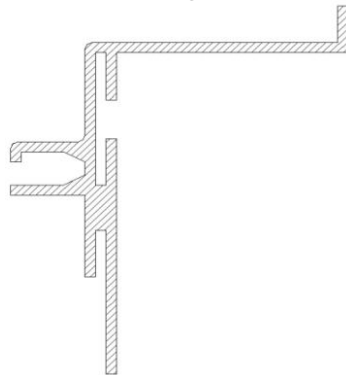

1. Impregnated pre-compressed foam sealing tap
2. Drainage space
3. Pre-compressed foam sealing tape, used as insulation and bottom cleat
4. Elastic sealant
5. Aluminum frame
6. Water barrier
7. Cellular rubber
8. Elastic sealant
9. Window sheet
10. Cement based sheet

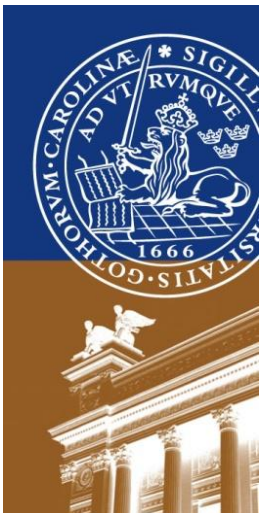

Horizontal section (early version of the profile)

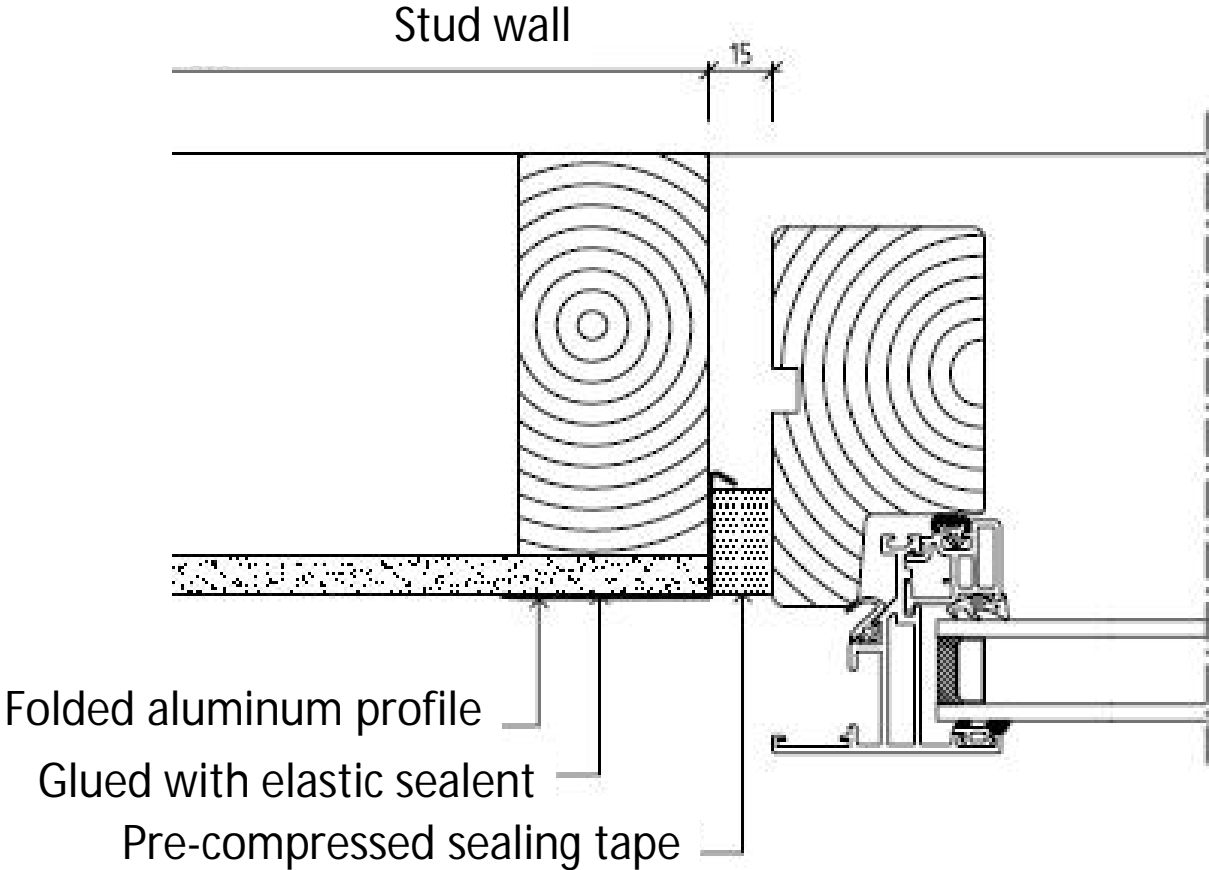

Pilot study- with the simple prototype

Water penetration test according to test standard EN 1026/1027

No facade material mounted

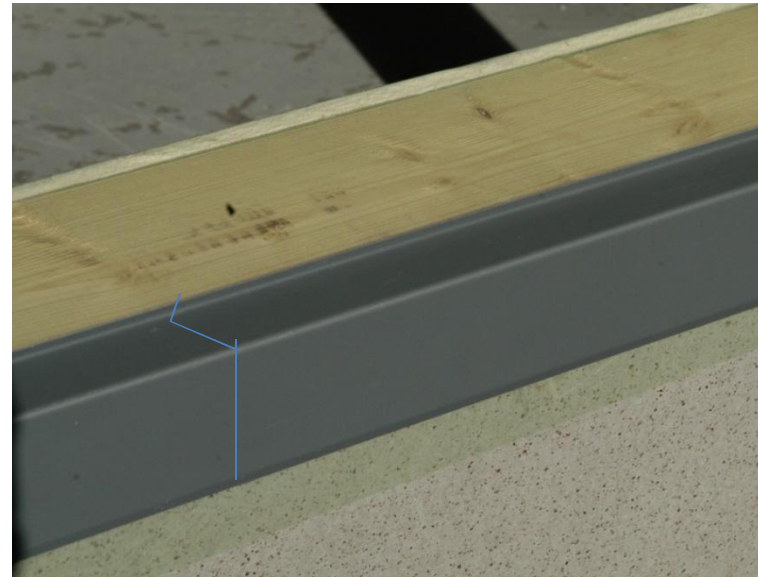

Results from the first water penetration test

Positive results

- no water penetration between the folded aluminum profile and stud wall

Negative results

- water penetration due to incorrectly mounted pre-compressed sealing tape at the lower corners



New test showed that it was possible to pass the test, with minor adjustments

Prototype wall 1 - ETICS



Fig. 2a. Wall with external insulation and plaster.

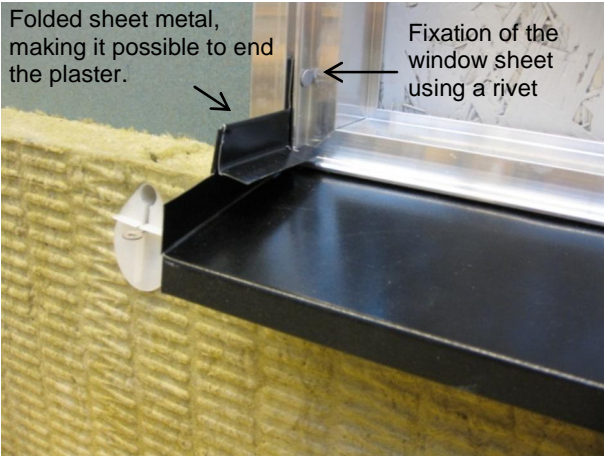

Fig. 2b. Lower left corner before plaster.



Fig. 2c. Lower right corner after plaster.



Fig. 2d. Upper right corner after plaster.

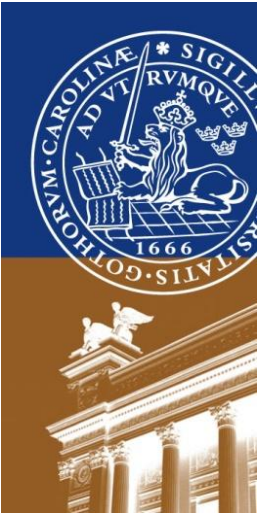

Prototype wall 2- wooden panelling



Fig. 3a. Wall with wooden panelling



Fig. 3b. Lower right corner before covering with window sill



Fig. 3c. Lower right corner after mounting the window sill.



Fig. 3d. Upper right corner after mounting the window sill.

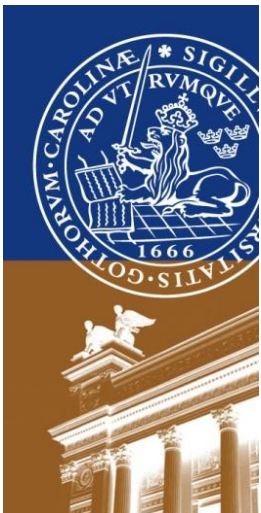

Prototype wall 2- wooden panelling completed with window

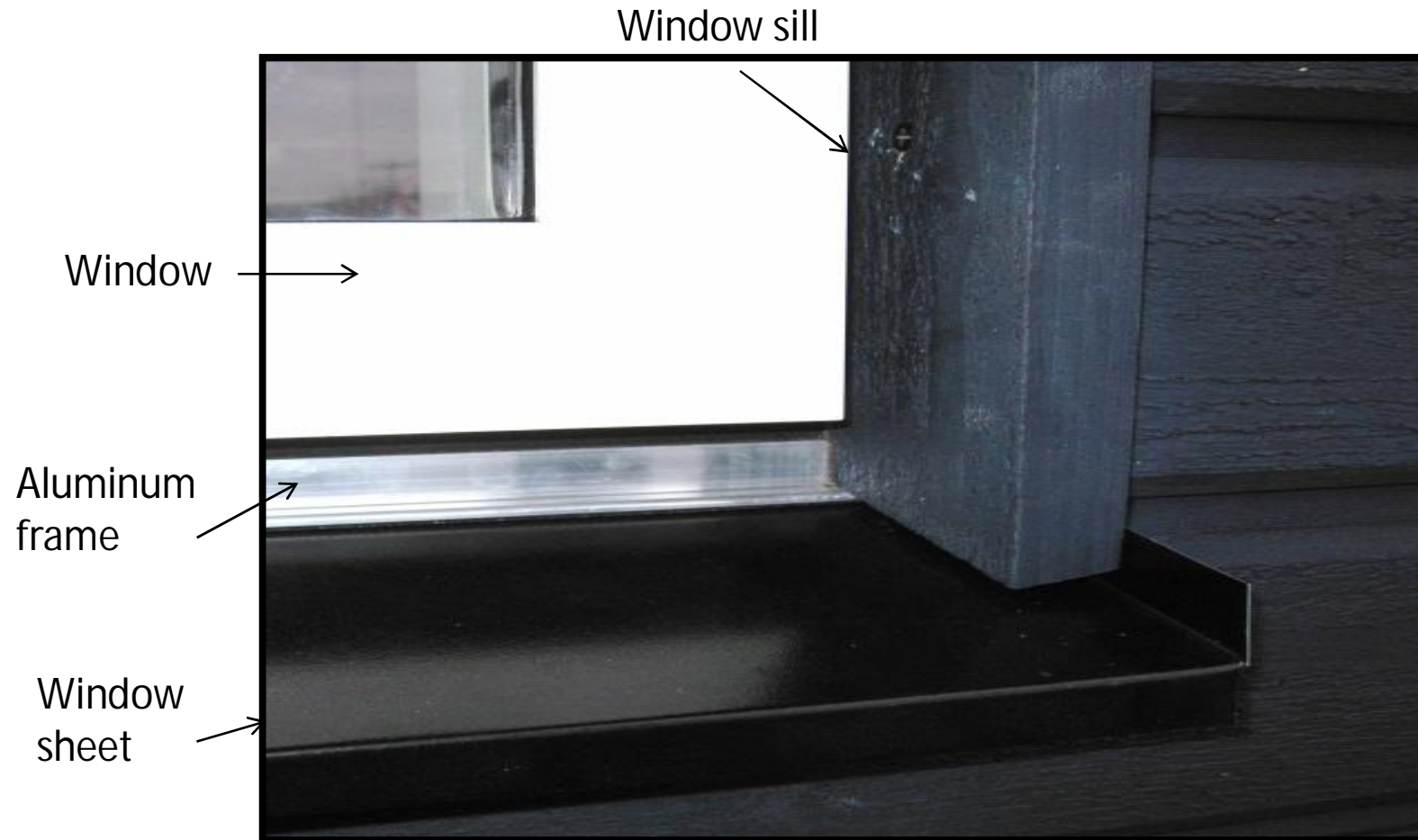

Lower right corner, complete with window. The aluminium frame is only visible at the bottom of the window

Conclusions

- The developed aluminum frame was adapted to a certain type of window
- The concept is of course compatible to other manufacturers' windows with minor modifications
- A disadvantage of using aluminum is its high thermal conductivity
- Other materials such as pvc or composites are possible to be used
- The corner of the frame is glued together with an elastic sealant – not optimal
- Welding or prefabricated corners is a possible solution
- The window sheet should also be prefabricated, to be able to get the optimal fit and the right design to complete the façade

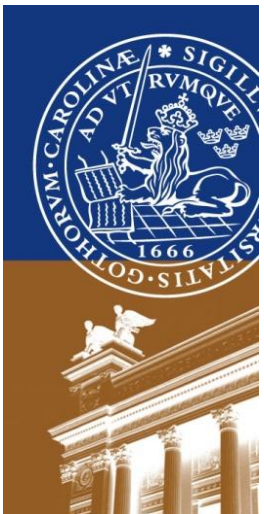

Further work

- Due to the financial crisis during 2009, the collaboration with the window manufacturer was stopped - therefore no commercial product is on the market
- The development work will probably be restarted during 2012 in a new project.

Funding from VINNOVA through LWE –Lean Wood Engineering is acknowledged

